

SMiDSY

Electronic Motorcycle Visibility Aids

TSR-1 MOTORCYCLE TURN SIGNAL REMINDER MODULE

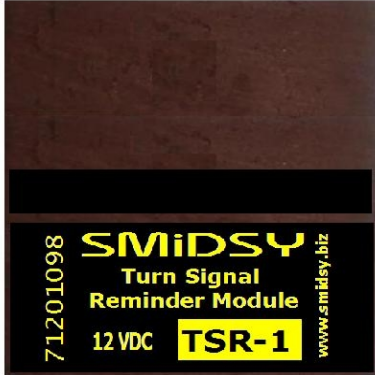

SMiDSY TSR-1 OPERATION

UPON APPLYING EITHER RIGHT OR LEFT TURN SIGNALS, THE UNIT WILL PRODUCE A GENTLE BLIPPING NOISE WITH EACH FLASH. AT THE SAME TIME, THE UNIT WILL BEGIN TO COUNT THE NUMBER OF FLASHES MADE BY THE TURN SIGNAL. IF THE NUMBER OF FLASHES REACHES 24 THE UNIT WILL PRODUCE A LOUD TRIPLE FREQUENCY TONE. IF THE BRAKES ARE APPLIED, FOR EXAMPLE, AT JUNCTIONS, TRAFFIC SIGNALS ETC., OR THE TURN SIGNAL IS CANCELLED, THE COUNTER WILL RESET TO ZERO.

General Installation

The best place to mount the TSR-1 unit is in the cockpit area. The unit may also be mounted at the rear of the bike, where making the connections is usually easier, but if your bike is very noisy, this is not recommended as the sound is attenuated considerably by seat cushion materials etc. The most difficult part of cockpit mounting is getting a connection from the brake light switch and if you have difficulty finding and tapping into the correct wire, then, because this wire only carries a tiny signal current, it is often easier to detach the spade connector from the front brake lever switch, bare the end of the spare piece of black wire supplied with the unit, push this into the spade connector and then reconnect to the brake switch. Make sure you have made the connection to the SWITCHED side of the brake switch. The other end of this wire now connects to the RED wire on the TSR-1 unit. See pictures below for a typical example.

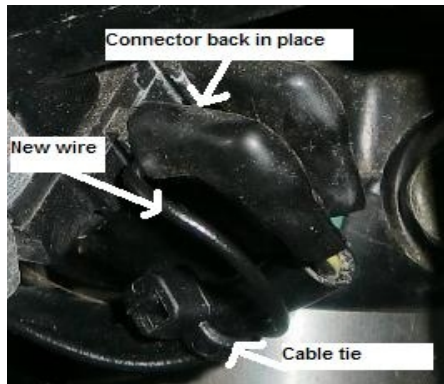
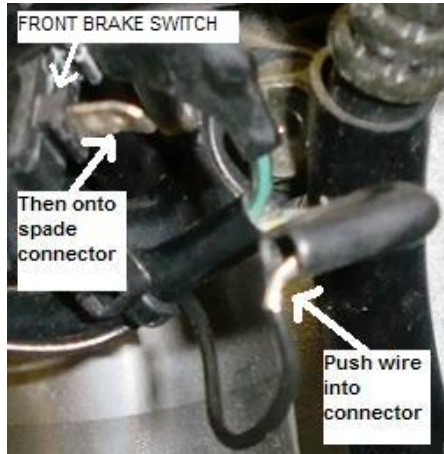

NOTE: THE UNIT WILL FUNCTION WITHOUT THE BRAKE WIRE CONNECTION (RED WIRE), BUT YOU WILL ONLY BE ABLE TO CANCEL BY TURNING OFF INDICATORS FOR APPROX ONE SECOND.

You can attach the unit anywhere convenient using cable ties, sticky pads, an existing screw through the mounting lug, whatever is suitable for your bike, just ensure that the unit or wiring does not interfere with any moving parts of your bike and that wires are not stretched at handlebar turn limits.

TSR-1 Wire Identification:

RED +12V Brake Light Supply
YELLOW Left Indicator
YELLOW Right Indicator
BLACK Ground

You can identify the wires to connect to with an electrical meter, from a workshop manual, trial and error or, if you get really stuck, buy a mate with electrical knowledge a beer or two). You can also contact us by email support@smidsy.biz and we'll do our best to help.

Testing

Switch on the Right Turn signal and the TSR-1 will produce a "Blipping" noise in time with the flashing. When the Turn Signal has flashed 24 times, the TSR-1 will produce a loud triple frequency tone to remind you your turn signal is still activated. Now apply the brakes, and the TSR-1 will revert to the "Blipping" noise. Repeat the above test with the Left Turn Signal.

NOTES: The unit self cancels after 20 warning tones to allow use of Hazard Flashers if fitted to your bike.

The TSR-1 unit is waterproof, but never direct a high pressure water jet at the unit.

WARRANTY

We hope you will be pleased with your purchase. All SMiDSY products are fully tested after assembly. This product is guaranteed against malfunction or manufacturing defects for a period of 12 months from the date of purchase, provided the unit is installed in accordance with these instructions. Your statutory rights are not affected.

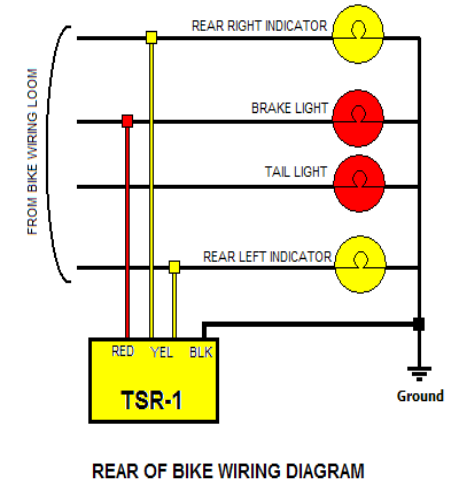
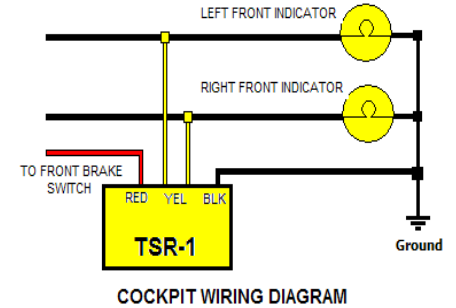

www.SMiDSY.biz
www.SMiDSY.eu